



15/25 kV Primary Metering Equipment
200/600 Amp Pad-Mounted Outdoor

Data Sheet
400.1.1
Page 1 Rev A.

Application:

Shallbetter Inc. SPMD Padmounted Primary Metering Gear is constructed in accordance with the latest applicable industry standards and the local and/or National Electrical Code requirements.

The Shallbetter Inc. SPMD Padmounted Primary Metering Gear is intended for use where the service is fed from underground and the revenue metering is measured at the primary voltage rate.

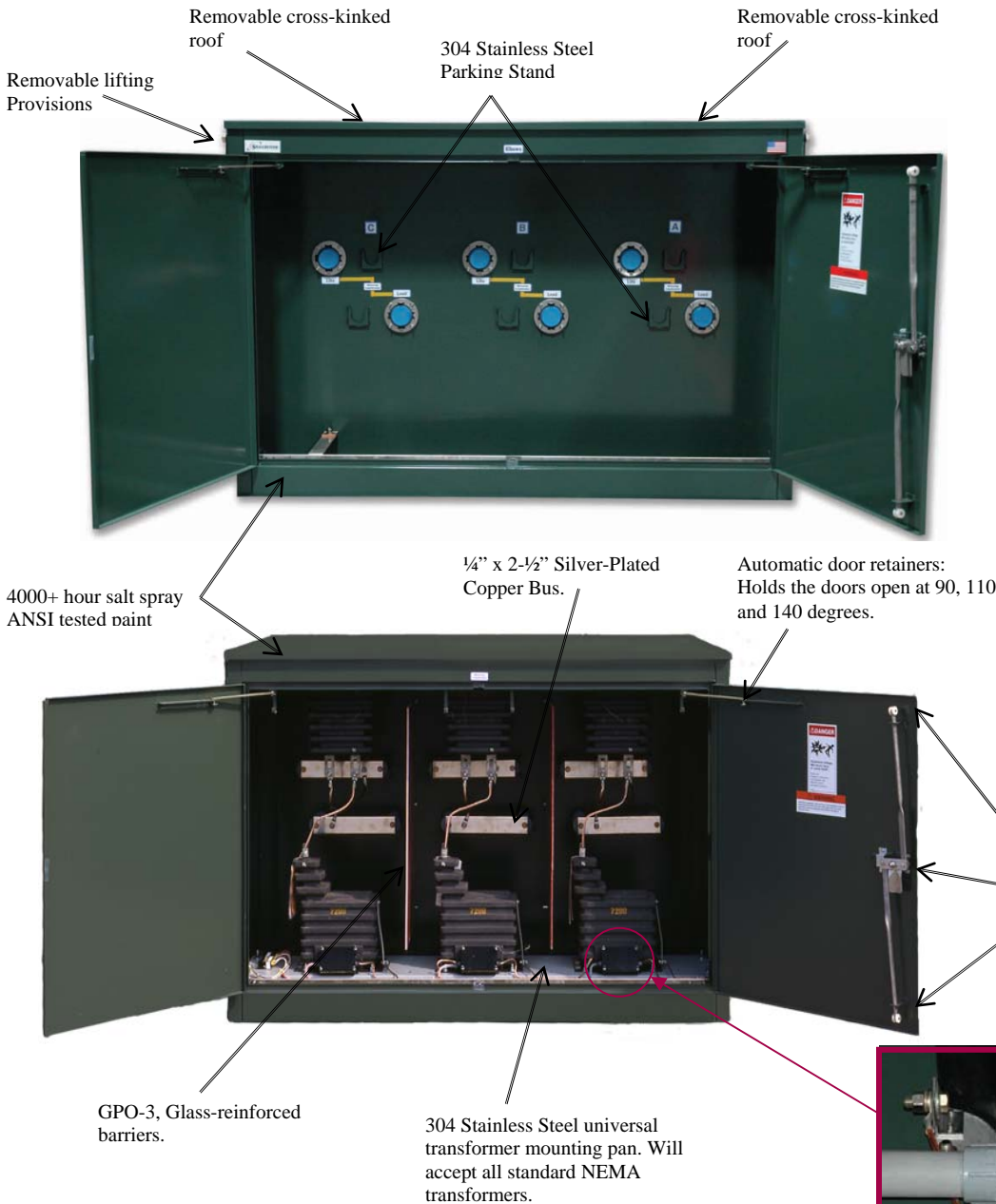

Field-Proven Components:
Bushing / Bushing Wells specifically designed for "in-air" operation give you long term reliable service.

Standard Cable Training:
Quick economical installation assures proper operation for the life of the equipment.

Deep Elbow Compartment:
Placement of Bushing / Bushing Wells and parking stands makes switching and grounding easier and safer.

Tamper-Resistant Enclosure:
Meets National and Regional Enclosure Integrity Standards. Designed to eliminate the entrance of airborne contamination.

"In-Air" Insulation:
Eliminates leaking or contamination of insulating medium for long trouble-free operation.

"In-Air" Visibility:
Allows visual inspection of all components without having to De-energized the equipment for inspection.

"In-Air" Accessibility:
Means every connection may be checked and tightened using hot stick tools without De-energizing the equipment.

Automatic door retainers: Holds the doors open at 90, 110 and 140 degrees.



Concealed Color-coded control wire.

Enclosure Options:
1) 0.125" #5052H32 grade Aluminum
2) 12-Gauge 304L Stainless Steel
3) PMS or Pantone custom colors per your requirement.

Shallbetter Inc.
3110 Progress Drive
Oshkosh WI 54901



Phone (920) 232-8888
Fax (920) 232-8977
www.shallbetter.com



15/25 kV Primary Metering Equipment
 200/600 Amp Pad-Mounted Outdoor

Data Sheet
400.1.1
 Page 2 Rev A.

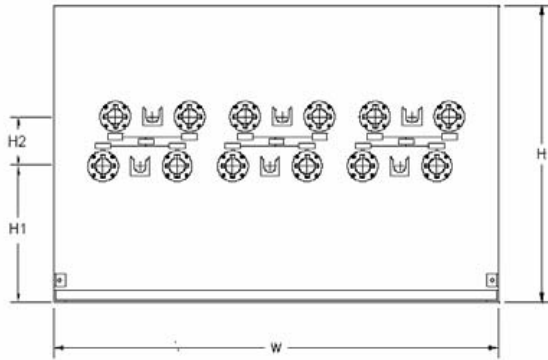

FRONT VIEW EXPOSED

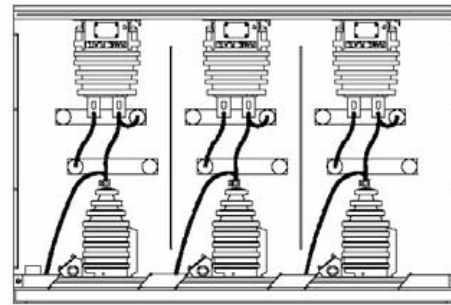

BACK VIEW EXPOSED

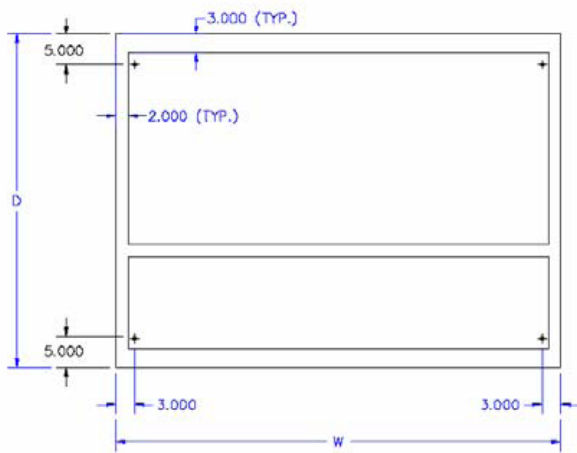

BASE PLAN

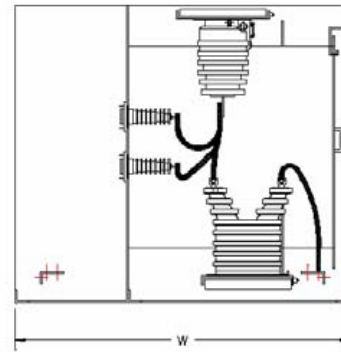

SIDE VIEW EXPOSED

Style	KV	H	W	D	H1	H2
SPMD-115	15	48	36	54	22	8
SPMD-125	25	48	36	54	22	8
SPMD-135	35	60	48	84	24	10
SPMD-315	15	48	72	54	22	8
SPMD-325	25	48	72	54	22	8
SPMD-335	35	60	96	84	24	10

Line Termination	Load Termination	1 line Diagram	3 line Diagram
1	1		
2	1		
1	2		
2	2		





Catalog Selection Guide

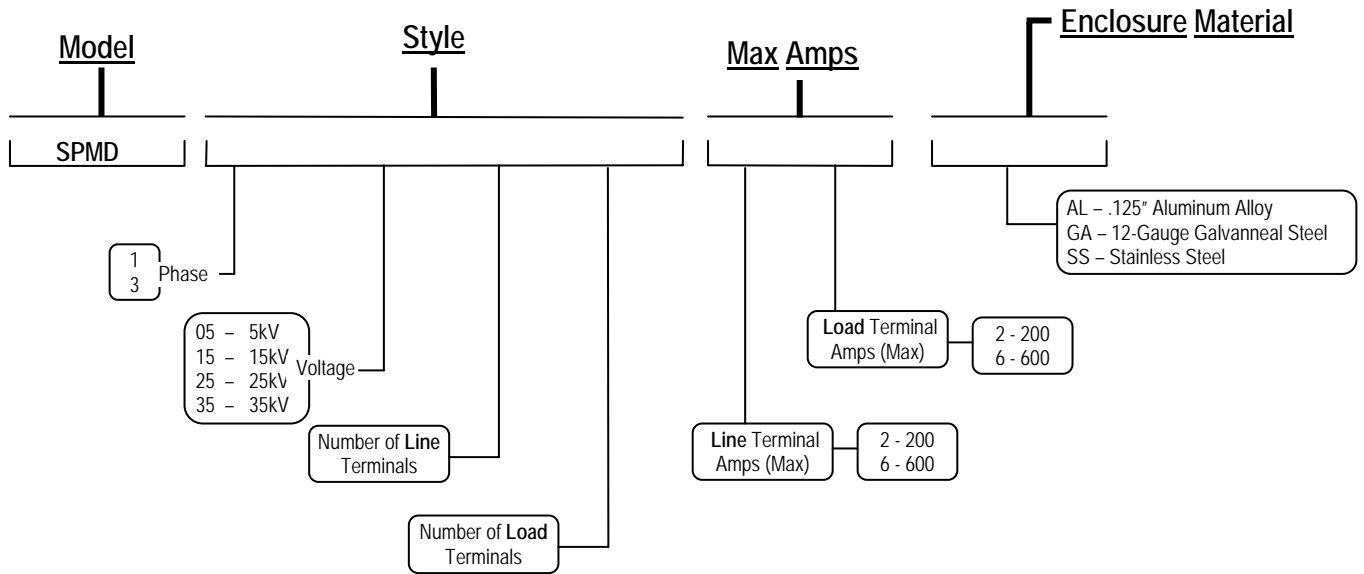

Factory Check Sheet

Paint Finish:

- Green. Munsell No., 7GY 3.29/1.5
- Gray (ANSI 70). Munsell No., 8.3G 7.0/0.4
- Gray (ANSI 61). Munsell No., 8.3G 6.10/0.54
- Other: _____

3-Point Latch Type:

- Penta-Head Bolt and shielded padlockable shackle, Shallbetter #70155. Manufactured to meet or exceed A.N.S.I. C57.12.28 for Padmount Equipment Enclosure Integrity.
- Hex-Head Bolt and shielded padlockable shackle, Shallbetter #70156
- Padlocking Handle, Shallbetter #70153

Metering Compartment Barriers, (Model SPMD only):

- 3/16", Glass Reinforced Polyester, (standard).
- 1/4", Clear Polycarbonate (Lexan), Replaces 3/16" Glass Reinforced Polyester Compartment Barriers.

Instrumental Transformers:

- Current Transformers: Manufacturer: _____, Model: _____, Type: _____, kV: _____, Ratio: _____.
- Potential Transformers: Manufacturer: _____, Model: _____, Type: _____, kV: _____, Ratio: _____.

Meter Socket: Manufacturer: _____, Model: _____, Type: _____.

Louvers for enclosure ventilation.

Insulation "No-Drip" Compound. Applied to the inside surface of the enclosure roof to prevent condensation.

Base Undercoating. Applied to the bottom 2" of the enclosure.

REA Deadfront Barriers. Barriers inside the enclosure door for each compartment, secured by recessed penta-head bolt.
 Note: Replaces compartment barriers, (Models SPMD only).

Rodent Plate. Seals base of enclosure, Metering Compartment side only, (Model SPMD only).

Terminal Adapters. Allows "piggybacking" of cables in switch and bus compartments.

Ground Bails. (Located on the Deadfront, Model SPMD only).

Interface Bushing Well Inserts. (200 amp only).

Specials:



Typical Specification

General

This specification covers the requirements for furnishing and delivering a self-contained, 15kV or 25kV rated, Shallbetter, Inc. Pad-Mounted Primary Metering Deadfront (SPMD) enclosure.

Standards

The primary metering equipment furnished shall comply with the material and testing requirements of the latest revisions of all applicable ANSI, IEEE, and NEMA standards.

Ratings

The primary metering enclosure shall have the following ratings:

- Nominal Design Voltage ___kV
- Maximum Design Voltage 15/25kV
- Basic Impulse Level (BIL) 95/125kV
- Continuous Current 200/600 Amps

Enclosure

The cabinet shall be of 12-Gauge Galvanneal steel. The enclosure shall be of an all welded construction (bolting and after welding, is not acceptable). All welds on the roof, doors and cabinet corners are to be ground smooth. The base shall be square and smooth to enable it to rest solidly on a level concrete or fiberglass pad. The Deadfront wall shall provide additional support to the roof and form a one-piece barrier between the termination and metering transformer compartments. The cabinet shall meet or exceed ANSI C57.12.28 tamper resistance requirements.

Roof

The cabinet roof shall be cross-kinked for water shedding in all directions.

Access

Access into the cabinet shall be through the doors to the termination and metering transformer compartments only. The design of the enclosure and components shall be arranged so all components are completely visible without any disassembly of the cabinet.

Doors

All doors shall include a true three-point latching mechanism that requires the doors to be securely latched before the padlock shackle can be inserted. The door handles shall be pad lockable and shall use a hood to protect the padlock from tampering. This door-latching scheme shall require only a single padlock per door or per set of double doors. Each door handle shall be provided with a recessed 304L stainless steel Penta head bolt as part of its security system. Doors shall be equipped with 304L stainless steel hinge assemblies and hinge pins. Each door shall be equipped with a 304L stainless steel door-holder located at the top of the enclosure doors. These holders shall be hidden from view when the door is closed. It shall not be possible for the door-holders to swing inside the enclosure. The door-holders shall lock in place automatically and hold the doors open at an angle of 90, 110, and 140 degrees. Manual insertion of the door holder in a locked position is not acceptable.

Barriers

Insulating inner phase and end barriers of red fiberglass reinforced polyester (NEMA rated GPO-3) shall be provided if required to achieve proper clearances in the metering transformer compartment. Front hanging compartment barrier in the metering transformer compartment shall be of (red fiberglass reinforced polyester NEMA rated GPO-3) or (1/4 inch clear polycarbonate "Lexan). All compartment barriers shall be equipped with non-conductive handles for ease of handling during installation and removal.

Lifting Tabs

Lifting tabs shall be removable. A resilient material shall be placed between the lifting tabs and the enclosure to prevent the tabs from **scratching the enclosure** finish. To help retard corrosion, this material shall be closed-cell neoprene to prevent moisture from being absorbed and held between the tabs and the enclosure.

Finish

The finish of the switchgear cabinet shall meet or exceed the requirements of ANSI C57.12.28. The topcoat of the finish shall be accordance with the specified color. Final finish coat shall be applied to minimum dry build of (6) six to (8) eight mils when dry.



Typical Specification – Continued

Grounding Provisions

A ground connection pad shall be provided in each compartment of the pad-mounted gear. The pad shall be welded to the interior of the enclosure near the cable entrances. The pad shall be unpainted 304L stainless steel. The pads shall be a minimum of 2" X 3-1/2" with 9/16" holes spaced 1-3/4" center to center.

Bus

All buses shall be of silver-plated copper. All joints shall have suitable hardware and treatment to prevent harmful oxidation and loss of optimum contact pressure.

Termination Compartment

Termination compartment shall have (200 Amp bushing wells) or (600 Amp bushings) to permit connection of elbows. Termination compartments shall be provided with one 304L stainless steel parking stand for each bushing or bushing well. The parking stand shall be located immediately adjacent to the associated bushing or bushing well and shall accommodate standard feed-thru and standoff insulators, and other similar accessories.

Bushing/Bushing Wells

Bushings or bushing wells shall conform to ANSI/IEEE Standard 386 (ANSI Standard C119.2). Bushings or bushing wells shall be mounted in such a way that the semi-conductive coating is solidly grounded to the enclosure. Bushings rated 600 amperes continuous shall have a removable threaded stud so that the bushing are compatible with all 600-ampere elbow systems—those requiring a threaded stud as well as those that do not. The 200A bushing wells shall be designed to accept standard load break bushing inserts.

Metering Transformer Compartment

The metering transformer compartment shall include the provisions for mounting _____ Potential Transformers and _____ Current Transformers. Transformer mounting pans shall be universal to accept NEMA outdoor metering transformers of the associated voltage class and made of 304L stainless steel. Cable tie support shall be welded to the metering transformer pan and the inside of the sidewalls to support secondary control wiring.

Labeling

The outside of each enclosure shall be provided with "Mr. Ouch WARNING" labels in accordance with NEMA 260. The inside of each enclosure door and each hanging barrier shall be provided with "Mr. Ouch DANGER" labels in accordance with NEMA 260. The labels shall have a minimum durability rating of 10 years under vertical exterior exposure to the weathering environment.

Nameplate

The outside of the primary metering cabinet shall have a non-corrosive nameplate indicating:

- Manufacturer's name
- Catalog no.
- Model no.
- Serial no.
- Date of manufacture

Circuit Diagram

The Deadfront wall on the termination side shall be provided with a circuit diagram of the switchgear.

Packaging

Each pad-mounted switchgear shall be secured to a non-returnable wood pallet suitable for handling with a forklift. The pad-mounted switchgear shall be packaged in accordance with good commercial practice to ensure safe delivery without damage to the finish or any other part of the unit.

Inspection

After delivery, each pad-mounted switchgear will be inspected for defects and conformance to this specification. The supplier (or its representative) will be notified of all deficiencies. Mutual arrangements shall be made for correcting the deficiencies.

Instrument Transformer Selection

15/25 kV class NEMA standard outdoor Current and Potential Transformers may be used in Shallbetter Inc. "SPMD" Primary Metering equipment shown in this bulletin.

When ordering with instrument transformers, specify:

- 1) CT ratio
- 2) PT ratio
- 3) Preferred brand

